

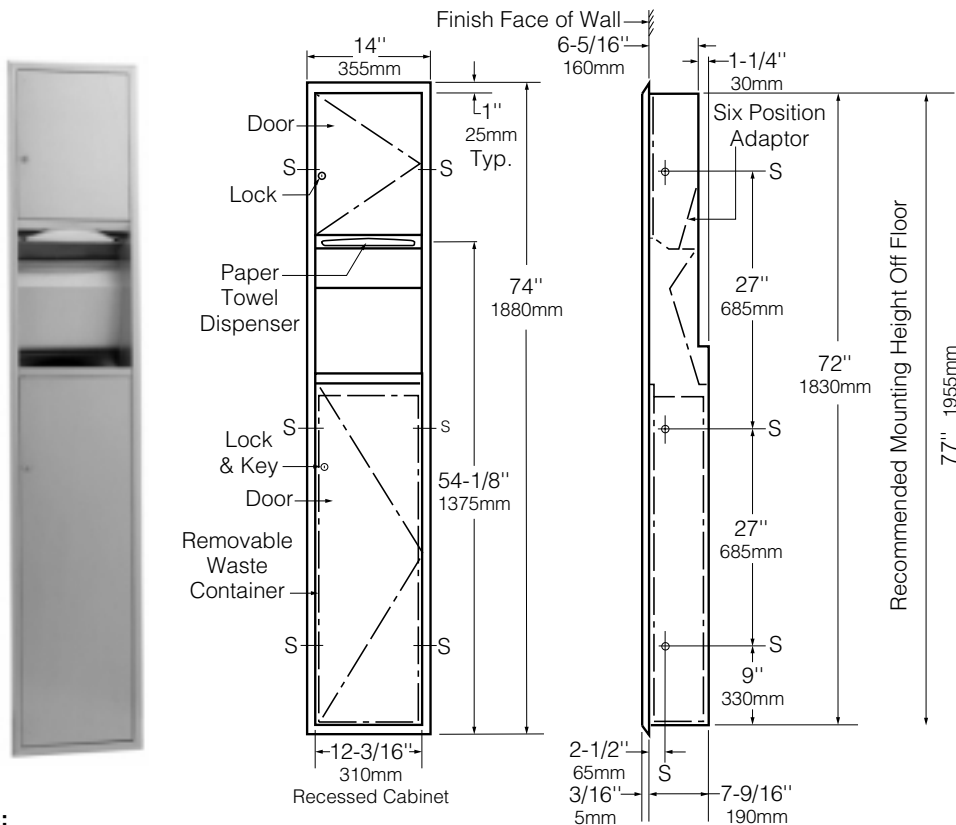

Technical Data

# RECESSED PAPER TOWEL DISPENSER AND WASTE RECEPTACLE

# B-360P



### MATERIALS:

**Cabinet** — 18-8 S, type-304, heavy-gauge stainless steel. All-welded construction. Exposed surfaces have satin finish.

**Flange** — 18-8 S, type-304, 22-gauge (0.8mm) stainless steel with satin finish. Drawn and beveled, one-piece, seamless construction.

**Doors (2)** — 18-8 S, type-304, 22-gauge (0.8mm) stainless steel with satin finish. Double-pan-back construction is warp-resistant. Secured to cabinet with full-length stainless steel piano-hinges. Equipped with stainless steel cable door-swing limiters and tumbler locks keyed like other Bobrick washroom accessories.

**Paper Towel Dispenser** — 18-8 S, type-304, 22-gauge (0.8mm) stainless steel. Six-position adapter adjusts to dispense C-fold, multifold, or singlefold paper towels. Rounded towel tray has hemmed opening to dispense paper towels without tearing. Capacity: 600 C-fold, 800 multifold, or 1100 singlefold paper towels.

**Waste Container** — Removable, leakproof, rigid molded plastic. Capacity: 10.5 gal. (39.7 L).

### OPERATION:

Paper towel dispenser is adjustable to dispense 600 C-fold, 800 multifold, or 1100 singlefold paper towels with use of six-position adapter. To service waste receptacle, unlock door with key provided and remove waste container. Cable door-swing limiters prevent damage to washroom accessories and walls.

### INSTALLATION:

Provide framed rough wall opening 12-1/2" wide x 72-1/2" high (320 x 1840mm). Recessed depth required to finish face of wall is 7-5/8" (194mm). Allow clearance for construction features that may protrude into opening from opposite wall. Coordinate with mechanical engineer to avoid pipes, vents, and conduits. If unit projects above top of wainscot, provide aluminum channel or other filler to eliminate gap between skirt and finish face of wall. Mount unit with shims between framing and cabinet at all points indicated by an S, then secure unit with sheet-metal screws (not furnished).

### SPECIFICATION:

Recessed paper towel dispenser and waste receptacle shall be type-304 stainless steel with all-welded construction; exposed surfaces shall have satin finish. Flange shall be drawn and beveled, one-piece, seamless construction. Doors shall be secured to cabinet with full-length stainless steel piano-hinges and equipped with stainless steel cable door-swing limiters and tumbler locks keyed like other Bobrick washroom accessories. Paper towel dispenser shall be equipped with an adapter capable of dispensing 600 C-fold, 800 multifold, or 1100 singlefold paper towels. Unit shall be furnished with a removable, leakproof, rigid molded plastic waste-container that has a capacity of 10.5 gal. (39.7 L). Manufacturer's service and parts manual shall be provided to the building owner/manager upon completion of project.

**Recessed Paper Towel Dispenser And Waste Receptacle shall be Model B-360P of Bobrick Washroom Equipment, Inc., Clifton Park, New York; Jackson, Tennessee; Los Angeles, California; Bobrick Washroom Equipment of Canada Ltd., Scarborough, Ontario; Bobrick Washroom Equipment Pty. Ltd., Australia; and Bobrick Washroom Equipment Limited, United Kingdom.**